

Geometry B Exam Review

The following formulas will be provided in the examination booklet:

Formulas for Area (A), Circumference (C), and Arc Length (L)

Area of a Triangle: $A = \frac{1}{2}bh$ $A = \frac{1}{2}ab \sin C$

Area of a Rectangle: $A = bh$

Area of a Trapezoid: $A = \frac{1}{2}(b_1 + b_2)h$

Area of a Parallelogram: $A = bh$

Area of a Regular Polygon:

$$A = \frac{1}{2}aP = \frac{1}{2} \times \text{apothem} \times \text{perimeter}$$

Circle Formulas

Area of a Circle: $A = \pi r^2$

Circumference of a Circle: $C = 2\pi r = \pi d$

Arc Length of a Circle: $L = \frac{m^\circ}{360^\circ}(2\pi r) = \frac{m^\circ}{360^\circ}(\pi d)$

Area of a Sector of a Circle: $A = \frac{m^\circ}{360^\circ}(\pi r^2)$

Area of a Segment of a Circle = Area of sector – Area of Triangle

Angle and Arc Formulas:

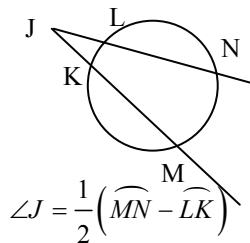
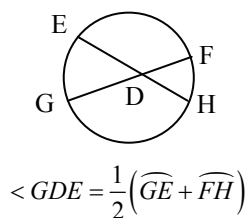
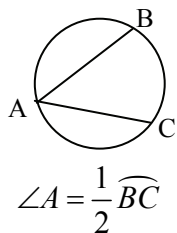

Formulas for Right Triangles

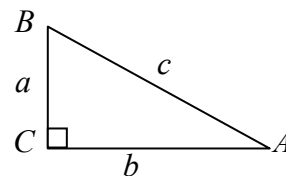

Pythagorean Theorem:
 $a^2 + b^2 = c^2$

$$\sin A = \frac{a}{c} = \frac{\text{opposite}}{\text{hypotenuse}}$$

$$\cos A = \frac{b}{c} = \frac{\text{adjacent}}{\text{hypotenuse}}$$

$$\tan A = \frac{a}{b} = \frac{\text{opposite}}{\text{adjacent}}$$

Special Right Triangles

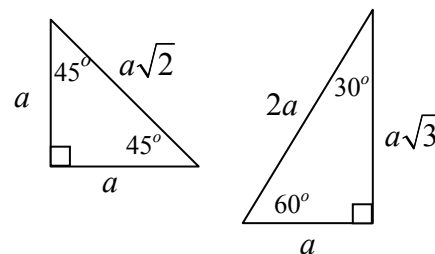

Coordinate Geometry Formulas

Let (x_1, y_1) and (x_2, y_2) be two points in the plane.

slope = $\frac{y_2 - y_1}{x_2 - x_1}$ where $x_2 \neq x_1$

midpoint = $\left(\frac{x_1 + x_2}{2}, \frac{y_1 + y_2}{2} \right)$

distance = $\sqrt{(x_2 - x_1)^2 + (y_2 - y_1)^2}$

Geometry B Exam Review

The following formulas will be provided in the examination booklet:

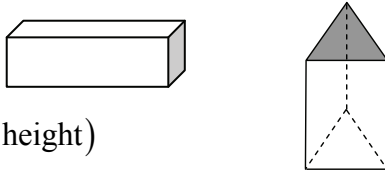
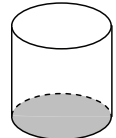
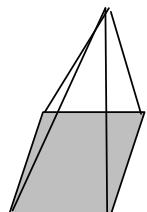
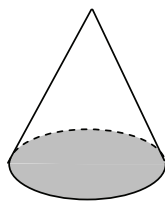
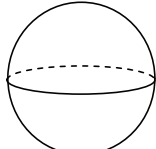
Formulas for Volume (V) and Surface Area (SA)	
<p>Right Prism</p> $V = Bh = \text{area of base} \times \text{height}$ $SA = 2B + Ph = 2 \times \text{area of base} + (\text{perimeter} \times \text{height})$	
<p>Right Circular Cylinder</p> $V = Bh = \text{area of base} \times \text{height} = \pi r^2 h$ $SA = 2B + Ch = 2 \times \text{base} + (\text{circumference} \times \text{height}) = 2\pi r^2 + 2\pi rh$	
<p>Regular Pyramid</p> $V = \frac{1}{3}Bh = \frac{1}{3} \times \text{area of base} \times \text{height}$ $SA = B + \frac{1}{2}Pl = \text{area of base} + \frac{1}{2} \times \text{perimeter of base} \times \text{slant height}$	
<p>Right Circular Cone</p> $V = \frac{1}{3}Bh = \frac{1}{3} \times \text{area of base} \times \text{height} = \frac{1}{3}\pi r^2 h$ $SA = \pi r^2 + \pi rl$	
<p>Sphere</p> $V = \frac{4}{3}\pi r^3$ $SA = 4\pi r^2$	
Other Formulas	
<p>Diagonal of a Prism $D = \sqrt{L^2 + W^2 + H^2}$</p> <p>Geometric Mean of Two Numbers $= \sqrt{a \cdot b}$</p>	

Geometry B Exam Review

For items 1 through 3, determine the area of the following composite figures. If the figure is shaded, find the area of the shaded portion of the figure.

Note: Figures NOT drawn to scale

1.

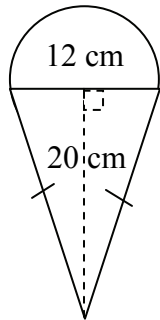

2.

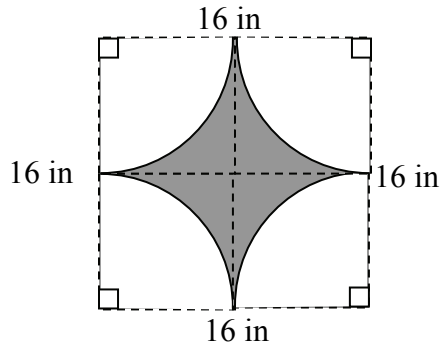

3. \overline{OR} and \overline{OS} are radii

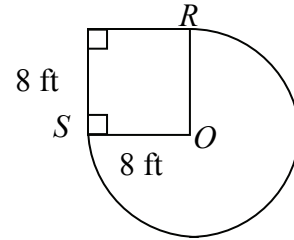

For items 4 and 5, determine the probability that a dart will hit the shaded area of the target.

4.

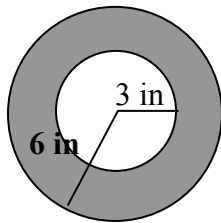

Note: Figure NOT drawn to scale

A $\frac{1}{4}$

B $\frac{1}{3}$

C $\frac{1}{2}$

D $\frac{3}{4}$

5.

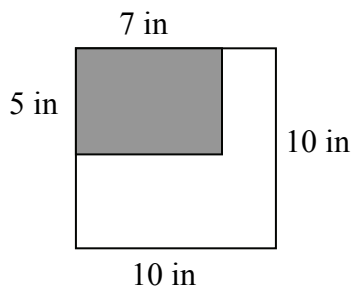

Note: Figure NOT drawn to scale

A $\frac{7}{20}$

B $\frac{3}{5}$

C $\frac{13}{20}$

D $\frac{7}{10}$

6. Which of the following statements are true?

- a. $\sqrt{7} \cdot \sqrt{5} = \sqrt{35}$
- b. $\frac{\sqrt{35}}{\sqrt{7}} = \sqrt{5}$
- c. $\sqrt{10} - \sqrt{3} = \sqrt{7}$
- d. $\sqrt{5} + \sqrt{6} = \sqrt{11}$
- e. $\sqrt{32} = \sqrt{16 \cdot 2} = 4\sqrt{2}$

For items 7 through 9, determine the distance between the following pairs of points.

- 7. (2, 6) and (5, 9)
- 8. (-3, 6) and (2, 1)
- 9. (-1, -1) and (2, 5)

10. Given: Quadrilateral *ROTS* with vertices as labeled below.

Show that: *If the midpoints of the sides of this quadrilateral are connected, then the figure formed has opposite sides that are congruent.*

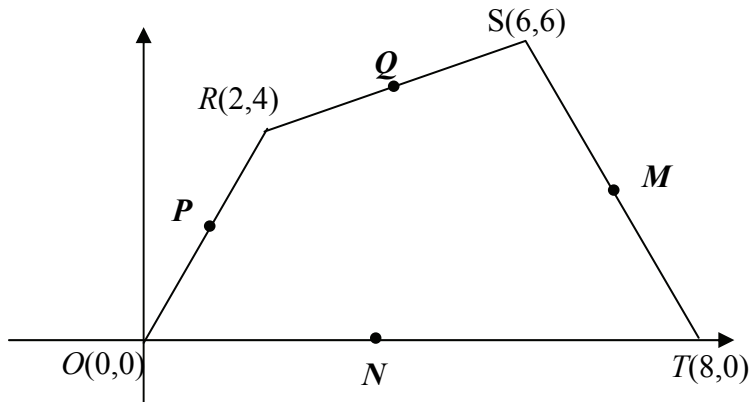

Geometry B Exam Review

11. Given: Right Triangle ABC with coordinates as shown. Point M is the midpoint of \overline{BC}

Find the area of triangle AMB

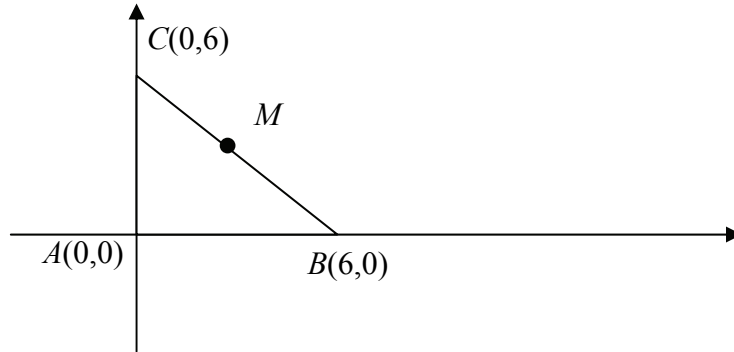

For items 12 through 14, the lengths of three segments are given. State whether the triangle formed by the three segments is acute, right, or obtuse. Give reasons for your answers.

12. 6, 8, 10 13. 3, 8, 9 14. 9, 12, 14

For items 15 through 23, determine the value of x and/or y in each figure below.

Note: Figures NOT drawn to scale

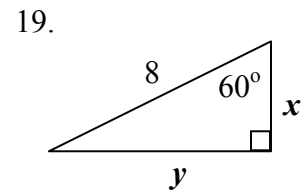
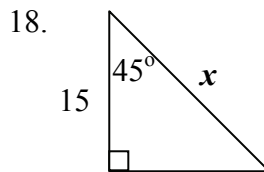
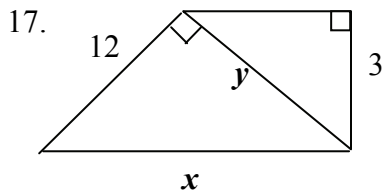
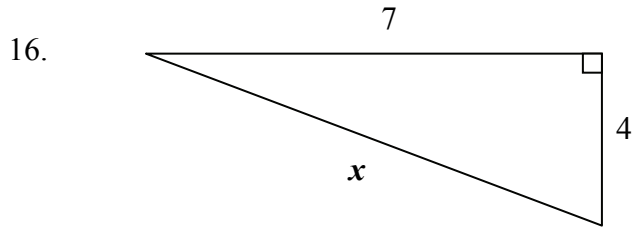
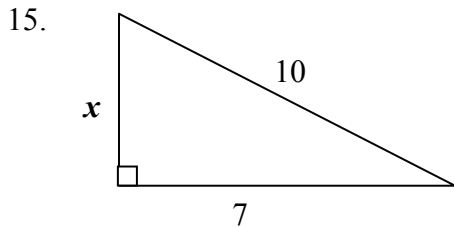

Geometry B Exam Review

20.

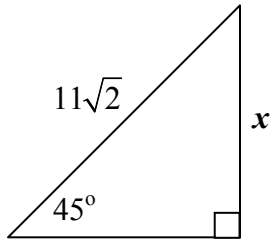

21.

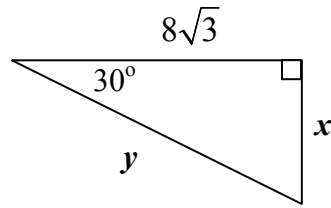

22.

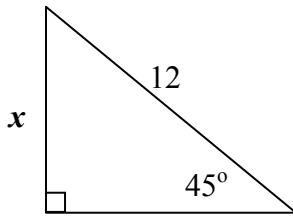

23.

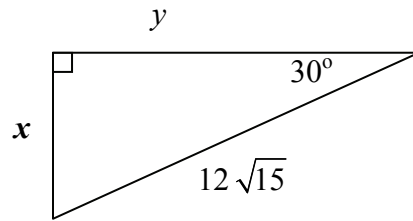

24. A regular hexagon has an area of $96\sqrt{3}$ and an apothem of $4\sqrt{3}$. What is the length of each side of the hexagon?

- A** 2 **B** 4 **C** 8 **D** $8\sqrt{3}$

For items 25 through 31, complete the information for each solid.

Note: Figures NOT drawn to scale

25.

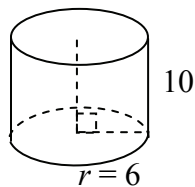

Surface Area: _____

Volume: _____

26.

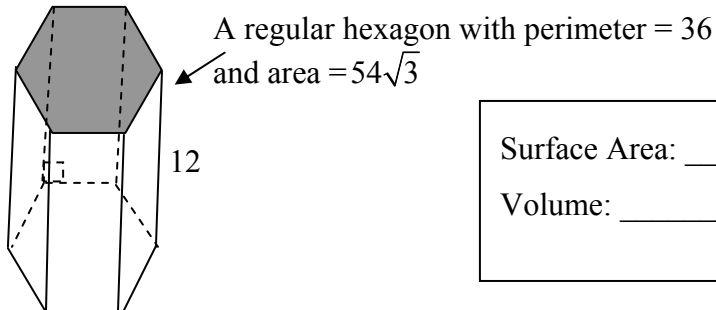

Surface Area: _____

Volume: _____

Geometry B Exam Review

27.

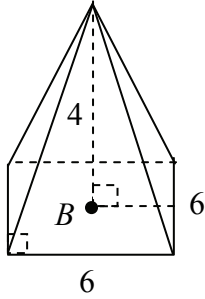

Point B is at the center of the square base.

Slant Height: _____
 Surface Area: _____
 Volume: _____

28.

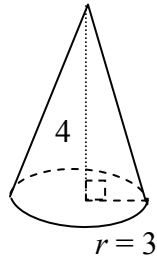

Slant Height: _____
 Surface Area: _____
 Volume: _____

29.

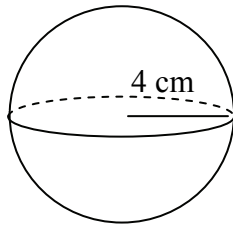

Surface Area: _____
 Volume: _____

30.

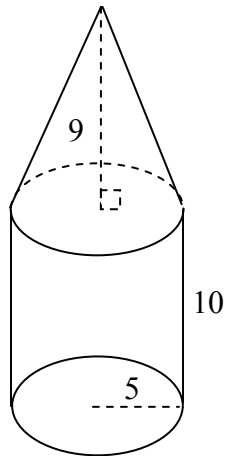

Surface Area: _____
 Volume: _____

31.

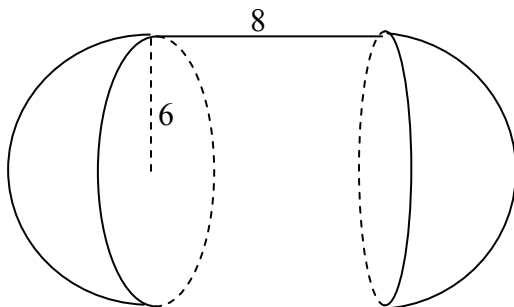

Surface Area: _____
 Volume: _____

32. If the radius of a sphere is doubled, what will happen to the surface area of the sphere?

- A It will increase by a factor of 2.
- B It will increase by a factor of 4.
- C It will increase by a factor of 6.
- D It will increase by a factor of 8.

33. If each side of a cube is doubled, what will happen to the volume of the cube?

- A It will increase by a factor of 2.
- B It will increase by a factor of 4.
- C It will increase by a factor of 6.
- D It will increase by a factor of 8.

34. Look at the right rectangular prism below.

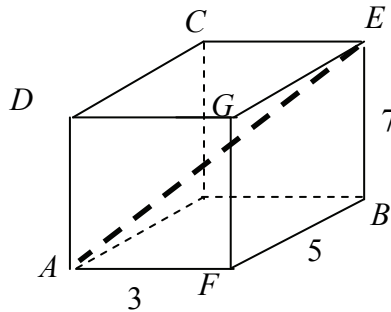

- a. What is the length of segment \overline{AE} ?
- b. What is the relationship between diagonal \overline{AE} and the prism?

35. A cube has a surface area of 24 in^2 . What is the volume of the cube?

36. In the figure below, the two cones are similar:

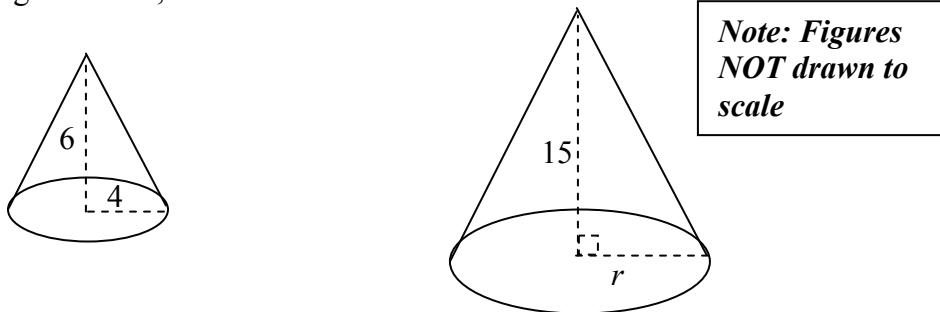

- a. What is the value of r ? Explain how you determined your answer.
- b. What is the ratio of the volumes of the cones? Explain how you determined your answer.

Geometry B Exam Review

37. If two polygons are similar, what is known about their angles and sides?

For items 38 and 39, the polygons are similar. Determine the value of x .

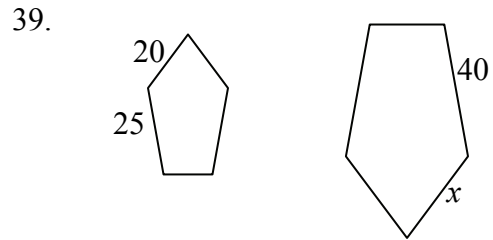
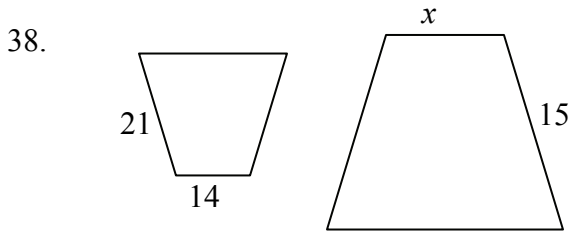

For items 40 and 41, determine the value of x in each figure below.

Note: Figures NOT drawn to scale

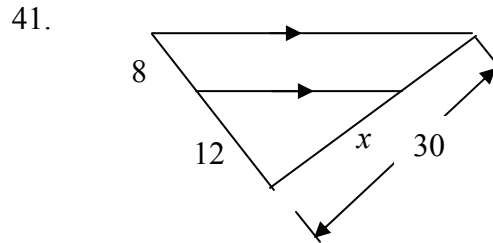
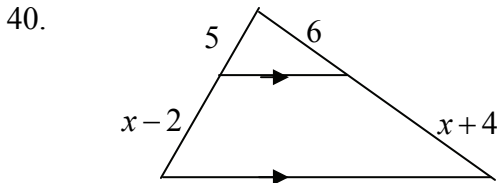

42. In the figure below, $\overline{AB} \parallel \overline{CD}$

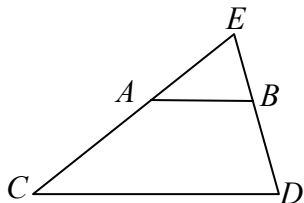

Note: Figure NOT drawn to scale

True or False?

- a. $\triangle EAB \sim \triangle ECD$
- b. $\frac{EA}{EC} = \frac{EB}{ED}$
- c. $\frac{EA}{AC} = \frac{EB}{BD}$
- d. $\triangle EAB$ is isosceles
- e. $AB = \frac{1}{2}CD$

43. In the figure below, $m \parallel n \parallel p$.

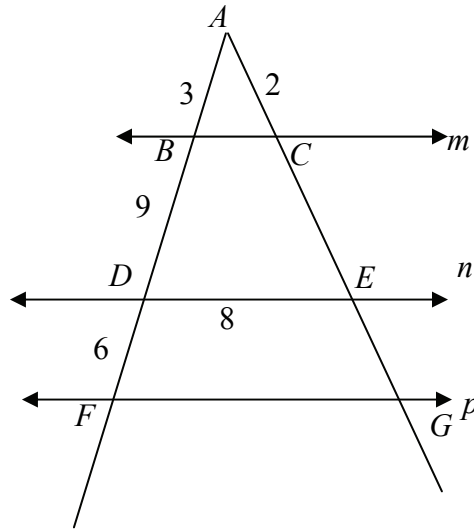

Note: Figure NOT drawn to scale

What is the perimeter of triangle AFG ? Explain how you determined your answer.

44. Look at triangles ABC and DCE below.

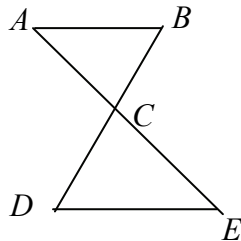

Note: Figure NOT drawn to scale

In parts (a), (b), and (c) below, determine whether the triangles are similar, based on the given information. Use mathematics to justify your answer.

- a. $\overline{AB} \parallel \overline{DE}$
- b. $BC = 14, AC = 16$
 $DC = 21, CE = 24$
- c. $AB = 10, BC = 20$
 $DE = 20, CD = 40$

Geometry B Exam Review

45. The ratio of the perimeter of two similar polygons is 5:7. What is the ratio of their areas?
46. The ratio of the volumes of two similar solids is 8:27. What is the ratio of their surface areas?
47. The ratio of the surface areas of two similar solids is 25:36. What is the ratio of their volumes?
- A** 5:6
B 25:36
C 125:216
D 625:1296
48. On the coordinate plane below, plot the points $A(-1, 2)$, $B(0, 1)$, and $C(2, 3)$

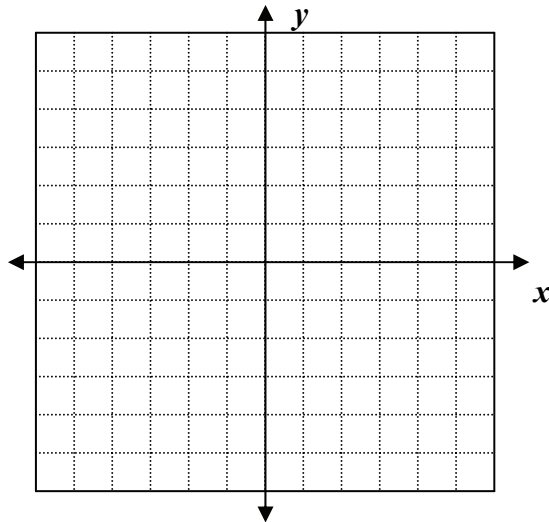

- Show that the triangle is a right triangle and determine its area.
- Using $(0,0)$ as the center of dilation and a scale factor of 2, draw the dilation image and state the coordinates of each vertex of the image.
- What is the ratio of the area of the dilation image to the pre-image? Use mathematics to justify your answer.

Geometry B Exam Review

49. Regular pentagon $PRSTU$ below has a perimeter of 60.
 It is dilated with a scale factor of $\frac{1}{3}$, with the center of dilation P to produce the shaded pentagon $PR'S'T'U'$.

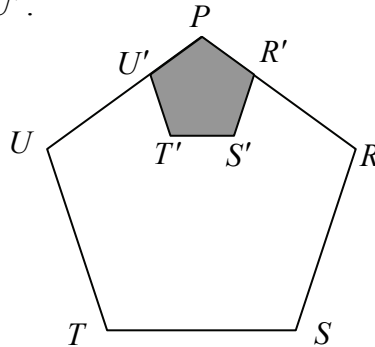

Note: Figure NOT drawn to scale

What is the length of $\overline{S'T'}$?

50. What is the geometric mean of 6 and 12?

- A $\sqrt{2}$ B $\sqrt{72} = 6\sqrt{2}$ C 18 D 72

For items 51 and 52, look at circle P below.

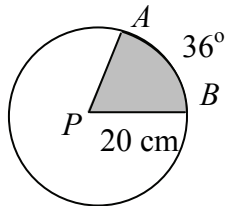

Note: Figure NOT drawn to scale

51. What is the length of \widehat{AB} ?
- A 4π B 8π C 80π D 160π
52. What is the area of the shaded sector?
- A 4π B 8π C 40π D 160π

Geometry B Exam Review

For items 53 through 55, find the value of the angle marked x°

Note: Figures NOT drawn to scale

53.

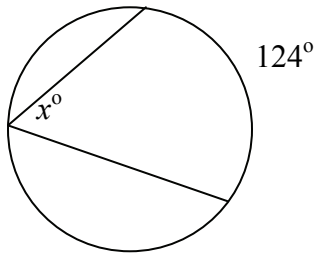

54.

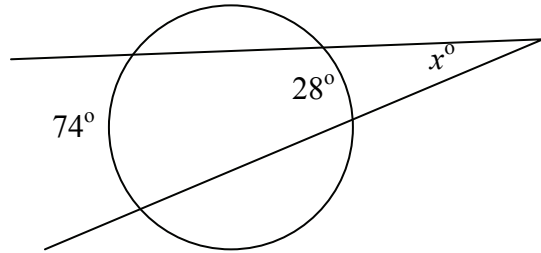

55.

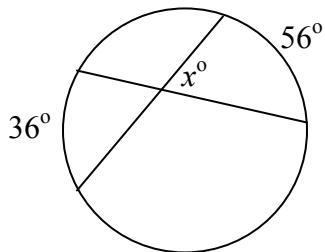

For items 56 through 68, find the value of the arc marked x° .

Note: Figures NOT drawn to scale

56.

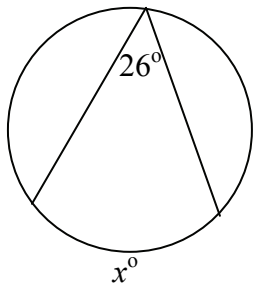

57.

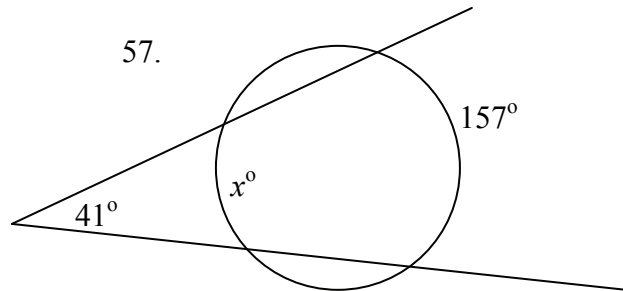

58.

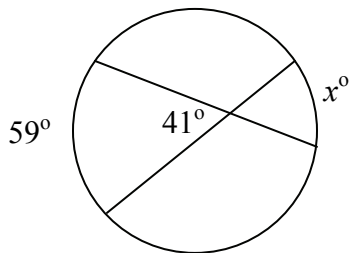

59. In circle E below,
 \overline{AB} is tangent to the circle at A .
 $m\widehat{AD} = 90^\circ$, $m\widehat{DH} = 40^\circ$, $m\widehat{GH} = 30^\circ$

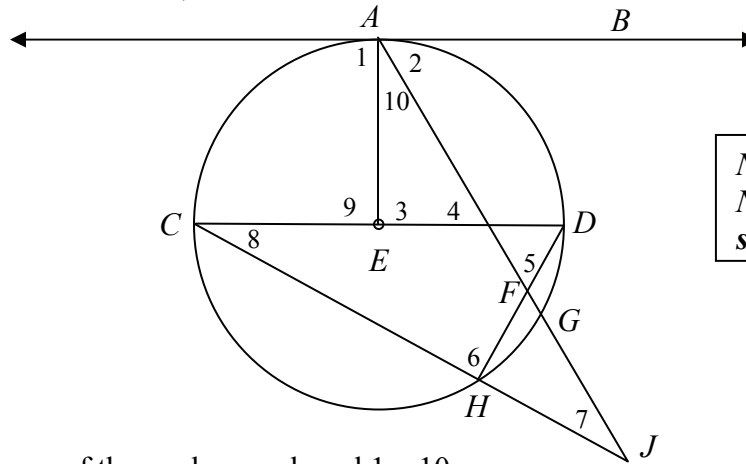

Note: Figure NOT drawn to scale

Find the measures of the angles numbered 1 – 10.

$m\angle 1 = \underline{\hspace{1cm}}$ $m\angle 2 = \underline{\hspace{1cm}}$ $m\angle 3 = \underline{\hspace{1cm}}$ $m\angle 4 = \underline{\hspace{1cm}}$ $m\angle 5 = \underline{\hspace{1cm}}$
 $m\angle 6 = \underline{\hspace{1cm}}$ $m\angle 7 = \underline{\hspace{1cm}}$ $m\angle 8 = \underline{\hspace{1cm}}$ $m\angle 9 = \underline{\hspace{1cm}}$ $m\angle 10 = \underline{\hspace{1cm}}$

60. For a game, a spinner is in the shape of a circle with radius 10 cm. The spinner is divided into sectors. One sector intercepts an arc of 72 degrees. What is the area of that sector?

For items 61 and 62, find the area of the shaded segments of the circles.

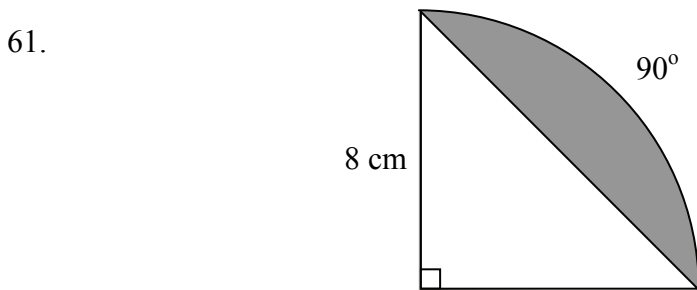

Note: Figure NOT drawn to scale

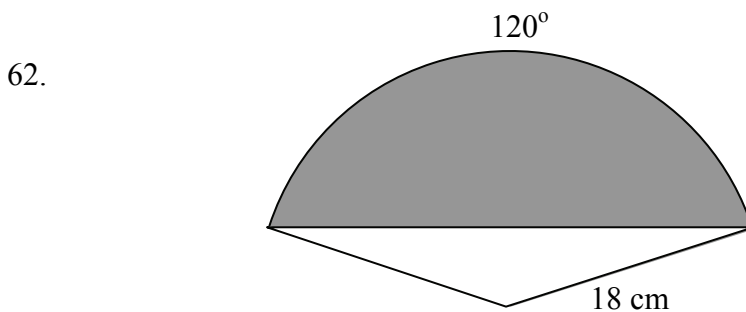

Note: Figure NOT drawn to scale

Note: Figure NOT drawn to scale

63. Circle O has a diameter of 20.
 $UT = 16$, $SM = 24$
 $\overline{RS} \perp \overline{UT}$, $\overline{RS} \perp \overline{SM}$

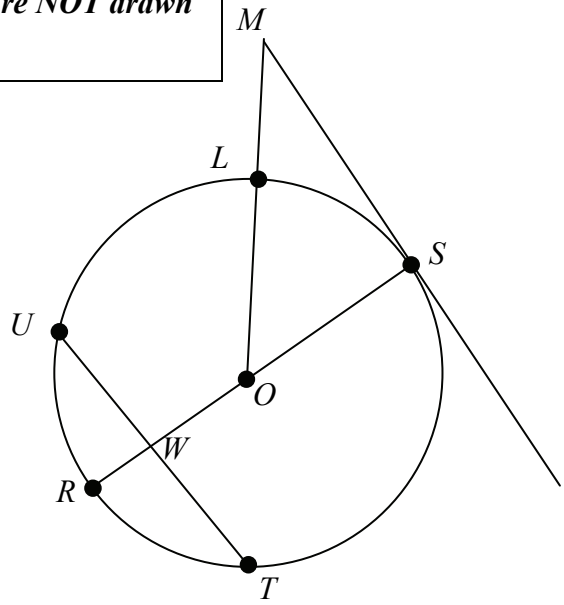

- a. What is the length of \overline{OW} ?
- b. What is the length of \overline{LM} ?
64. Describe and sketch the locus of all points in a plane that are equidistant from each endpoint of \overline{AB} .

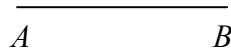

For items 65 and 66, look at the right triangle below.

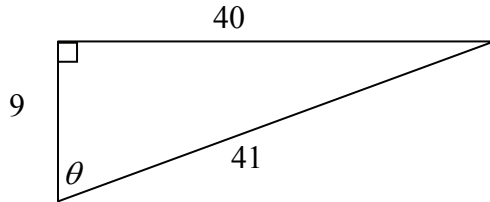

Note: Figure NOT drawn to scale

65. Which of the following has a ratio of $\frac{40}{41}$?
- A** $\sin \theta$ **B** $\cos \theta$ **C** $\tan \theta$ **D** None of these
66. Which of the following has a ratio of $\frac{40}{9}$?
- A** $\sin \theta$ **B** $\cos \theta$ **C** $\tan \theta$ **D** None of these

Geometry B Exam Review

For items 67 through 72, find the value of x .

67.

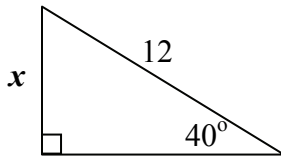

68.

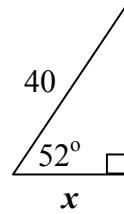

69.

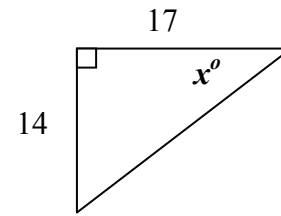

70.

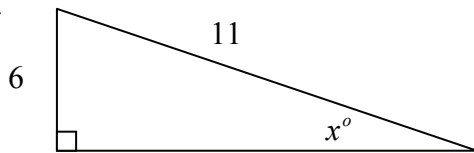

71.

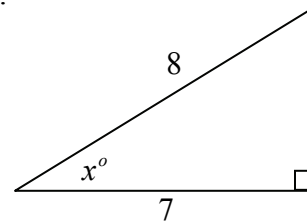

72. A jet plane begins a steady climb and flies for 3 miles (15840 feet) at an angle of 12° with the ground. What was its change in altitude in feet?